

**W90 Pro**

# User Manual

---

Cordless Wet & Dry  
Vacuum Cleaner

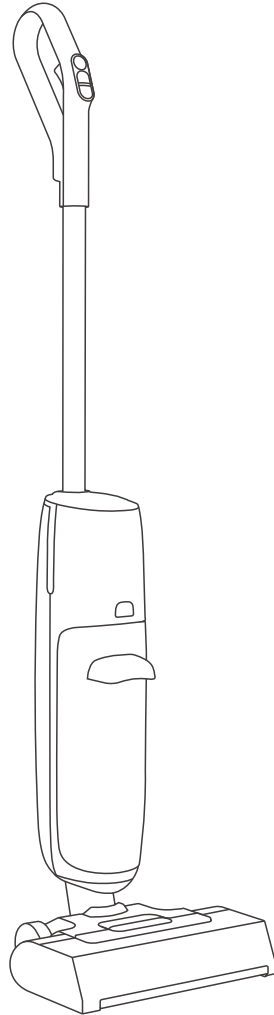

For more detailed information,  
please visit: [www.iliferobot.com](http://www.iliferobot.com)

**ILIFE**



Dear Customer,

Thank you for purchasing the ILIFE W90 Pro Cordless Wet & Dry Vacuum Cleaner! You've joined the millions of people cleaning with machines - the smartest way to do it.

Please take a few moments to read through this manual and familiarize yourself with your machine to achieve the best performance. If you encounter any issues with your machine, feel free to contact our customer service or visit our website at [www.iliferobot.com](http://www.iliferobot.com) for further assistance.

Stay connected with us on "X" to enjoy these exclusive benefits:

- Get tailored support for your specific machine, including answers to your questions, maintenance tips, video demonstrations, live chat, and more.
- Receive product updates and other valuable information, be among the first to discover new machines, exclusive discounts, and special promotions.

Connect with us now on

X: [https://x.com/ilife\\_Global](https://x.com/ilife_Global)

Enjoy comprehensive cleaning every day! Best regards,  
ILIFE Innovation

## ILIFE Customer Service



[service\\_asia@iliferobot.com](mailto:service_asia@iliferobot.com) (Asia)

[service\\_au@iliferobot.com](mailto:service_au@iliferobot.com) (Australia)

# Table of Contents

---

<b>1. Safety Instructions</b>	3
<b>2. Product Overview</b>	5
2.1 Package contents	5
2.2 Component identification	6
2.3 Display and buttons	7
2.4 Technical specifications	8
<b>3. Product Setup</b>	9
3.1 Handle installation	9
3.2 Charging dock connection	9
<b>4. Product Operation</b>	10
4.1 Filling the clean water tank	10
4.2 Locking, unlocking, and powering on	10
4.3 Mode switching & spraying	11
4.4 Powering off	11
4.5 Water level alerts	11
4.6 Emptying the dirty water tank	12
4.7 Charging and self-cleaning	13
<b>5. Maintenance and Care</b>	14
5.1 Recommended maintenance frequency	14
5.2 Cleaning the main body	14
5.3 Cleaning the dirty water tank and filters	15
5.4 Cleaning the roller brush	15
5.5 Cleaning the wastewater duct	16
5.6 Cleaning the charging dock	16
5.7 Replacing the floor brush squeegee	17
<b>6. Troubleshooting</b>	19
6.1 Malfunction status and solutions	19
6.2 Voice prompts & error codes	19

## 1.1 Safety Instructions

---

### Caution

- This appliance can be used by children aged from 8 years and above and persons with reduced physical, sensory or mental capabilities or lack of experience and knowledge if they have been given supervision or instruction concerning use of the appliance in a safe way and understand the hazards involved. Children shall not play with the appliance. Cleaning and user maintenance shall not be made by children without supervision.
- Avoid using the appliance in rooms where infants are sleeping.
- For indoor household use only. Do not use outdoors or in commercial or industrial environments.
- Use only accessories recommended or sold by the manufacturer.
- Use only official cleaning and disinfecting solutions provided by the manufacturer.
- Use only original rechargeable batteries and charging docks specified by the manufacturer. Ensure that the voltage matches the rating indicated on the charging dock.
- Ensure that the water tanks and filters are correctly installed before use.
- Do not use to vacuum foaming liquids such as detergent, soap water, or urine.
- Always turn off the machine and unplug the charging dock before performing cleaning or maintenance.
- Disconnect the device from power if it will not be used for an extended period.
- This appliance contains batteries that are only replaceable by skilled persons.
- **WARNING:** For the purposes of recharging the battery, only use the detachable supply unit (model: K25E280060B) provided with this appliance.
- A hazard may occur if the appliance runs over the supply cord.
- Follow the instructions in this manual. The manufacturer is not liable for damage or injury resulting from improper use.

## Danger

- Do not rinse the product directly with water.
- Do not wipe the product with a wet cloth.
- Do not operate the product near open flames or fragile objects.
- Keep body parts such as hair, fingers, and clothing away from the device's openings and moving parts.
- Do not use to vacuum hard or sharp objects such as construction debris, glass shards, or nails.
- Do not vacuum flammable substances such as gasoline, toner powder, or use in areas where such materials are present.
- Do not vacuum burning or smoking objects such as cigarettes or matches.
- Warning: Non-rechargeable batteries must not be recharged.
- This device contains a battery that must be replaced by qualified personnel only.
- Warning: Only use the original charging dock provided with the appliance.
- Warning: To prevent risk due to accidental reset of the thermal fuse, do not power the device through external switching devices (e.g., timers) or connect it to circuits that are frequently switched on and off by the utility.
- Do not install or charge the dock near heat sources or in humid areas (e.g., radiators, bathrooms).
- Do not use a damaged charging dock.
- Do not pull or drag the appliance or the dock by the power cord. Do not use the cord as a handle or trap it in doorways. Avoid pulling it around sharp edges or corners. Keep the cord away from hot surfaces.
- If the power cord is damaged, it must be replaced by the manufacturer, its service agent, or similarly qualified personnel.
- This appliance uses a rechargeable battery.
- Before disposal, remove the appliance from the dock, turn it off, and remove the battery.
- Always dispose of the battery according to local regulations.
- Do not incinerate the device even if severely damaged, as the battery may explode.

## 2.2 Package Contents

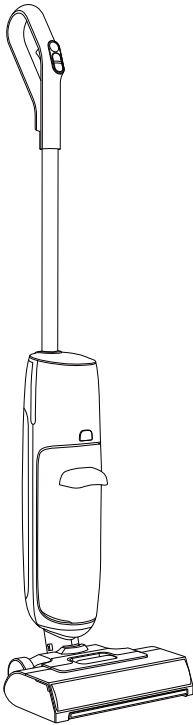

Main Body

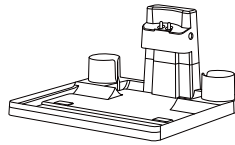

Charging Dock

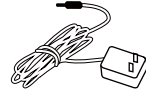

Adapter



User Manual



Extra Filter Sponge \*1



Cleaning Brush



Extra Squeegee \*2



Extra Roller Brush \*1

### Note:

Illustrations in this manual are for reference only. Actual product design and components may differ slightly due to product updates and enhancements. Please refer to the actual product.

## 2.2 Component Identification

### Main Body

- ① **Spray button:**  
Press and hold to spray water;  
release to stop spraying.
- ② Handle
- ③ Handle release hole
- ④ Voice speaker area
- ⑤ Clean water tank release button
- ⑥ Clean water tank handle
- ⑦ Clean water tank
- ⑧ Charging pins

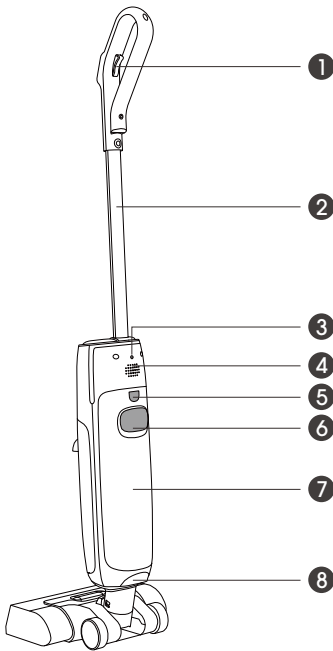

- ⑫ Battery display panel
- ⑬ Dirty water tank release button
- ⑭ Dirty water tank handle
- ⑮ Dirty water tank

- ⑨ **Power button:**  
Short press to power on/off
- ⑩ **Mode switch button:**  
Short press to switch between  
Auto/Max mode
- ⑪ **Self-cleaning button:**  
While charging, short press to  
start/stop self-cleaning

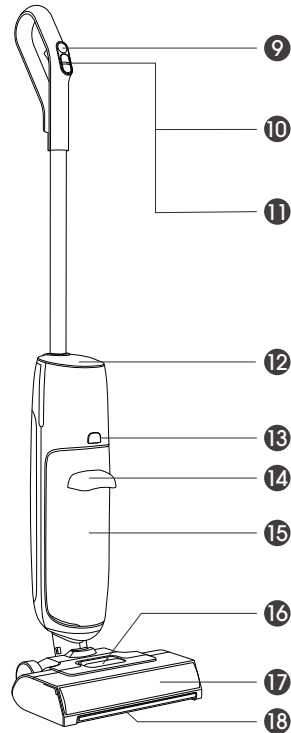

- ⑯ Roller brush cover release button
- ⑰ Roller brush cover
- ⑱ Roller brush

## Charging Dock

- ① Charging pins
- ② Power port
- ③ Brush/roller brush holder

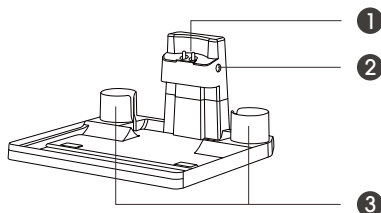



## 2.3 Display and Buttons

### Display Panel

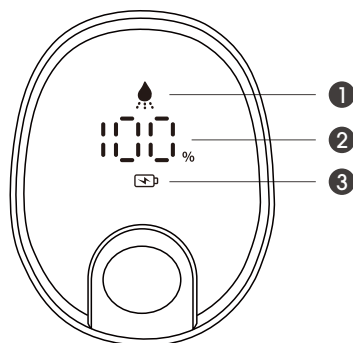
- ① Spray indicator (lights up when spraying)
- ② Battery/fault display
- ③ Charging indicator



### Button Functions

Button	Operation	Voice Prompt
 Power button	Short press to power on	Start cleaning
	Short press to power off	Power off, please put back the machine to the charging base.
 Mode switch button	Short press to switch modes	Auto mode / Powerful mode
 Self-cleaning button	Short press (while charging)	Start/Stop Self-Cleaning
	Long-press to switch languages (English, Russian, German, and Polish can be selected during operation).	Beep (then voice prompt in selected language.)

## 2.4 Technical Specifications

### Main Body

Specification	Details
Model	W90 Pro
Dimensions	280 × 236 × 1160 mm
Rated voltage	21.6 V
Rated power	150 W
Battery type	Lithium-ion
Charging time	< 300 min
Clean water tank capacity	0.6 L
Dirty water tank capacity	0.56 L
Net weight	4.16 kg

### Charging Dock

Specification	Details
Dimensions	295 × 281 × 150 mm
Rated input	28V $\rightleftharpoons$ 0.6A
Rated output	28V $\rightleftharpoons$ 0.6A
Rated power	16.8 W
Net weight	0.4 kg

#### Note:

- \* In order to continuously improve our products, we reserve the right to make any technical or design changes without prior notice.
- \* There are no functional differences between product variants; only colors or appearances may differ slightly.

### 3.1 Handle Installation

1. Insert the handle into the main body with the button facing forward. Push down until you hear a “click” indicating it is securely in place.
2. To remove the handle, Use a pointed object (e.g., a pen) to press the release hole on the back of the main body to press the spring, then pull the handle upward to detach.

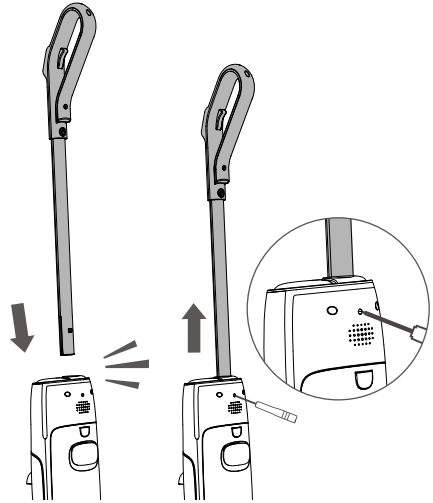

### 3.2 Charging Dock Connection

Place the charging dock on a hard, level surface. Plug the power adapter into the socket and connect to a power source.

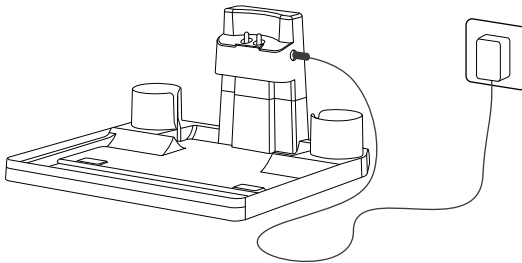

**Note:**

- \* Do not place the charging dock in damp or high-temperature areas such as bathrooms, kitchens, or near radiators.
- \* The cleaning brush can be stored in the rear holder slot of the charging dock. appearances may differ slightly.

## 4.1 Filling the Clean Water Tank

1. Hold the handle of the clean water tank and press the release button to pull it out.
2. Open the tank lid, fill with tap water (do not exceed the MAX line), then close the lid securely.
3. Tilt the tank slightly, insert the bottom part first, then push it inward until a “click” is heard to ensure proper installation.

**Tip:**

Do not use hot water to avoid tank deformation.

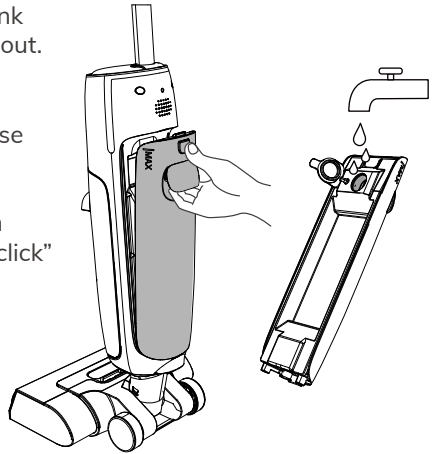

## 4.2 Locking, Unlocking & Powering On

1. Gently step on one side of the brush head and push/pull the handle to lock or unlock.
2. In the unlocked position, press the power button to start the machine.

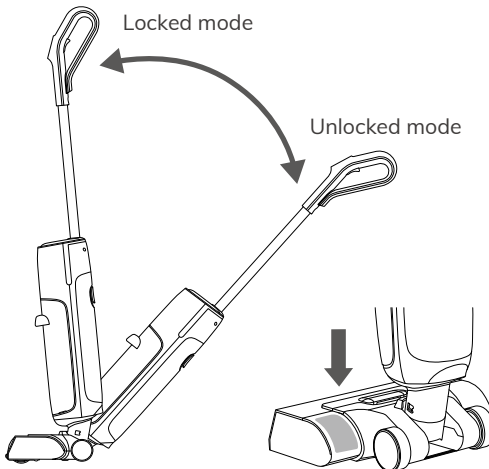

### 4.3 Mode Switching & Spraying

---

1. Short press the mode button to cycle between Auto and Max modes. A voice prompt will confirm the selected mode.
2. Press and hold the spray button to release clean water from the brush head. Control the spray duration by the length of the press. Release the button to stop spraying.

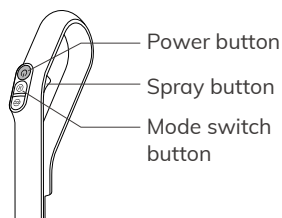

**Tip:**

When the spray button is pressed, the spray indicator on the display will light up. It turns off when the button is released.

### 4.4 Powering Off

---

1. While running, short press the power button to shut down. Push the handle forward to lock the main body in place so it can stand upright on the floor.
2. While powered on, placing the main body onto the charging dock will automatically turn it off.

**Tip:**

Standing the machine upright without pressing the power button will not power it off. Always press the button to shut down properly.

### 4.5 Water Level Alerts

---

1. When the dirty water tank reaches its maximum level during operation, a voice prompt will say “Please empty the dirty water tank.” Empty the tank before continuing use.
2. When the clean water tank is low, a voice prompt will say “Clean water shortage.” Please refill the tank.

## 4.6 Emptying the Dirty Water Tank

1. Hold the dirty water tank handle, press the release button, and pull the tank out.

2. Gently pull upward to remove the filter assembly and pour out the wastewater.

3. Remove the internal mesh filter to dispose of solid waste.

4. To reinstall, tilt the tank, insert the bottom part first, then push inward until a "click" is heard, confirming it is securely in place.

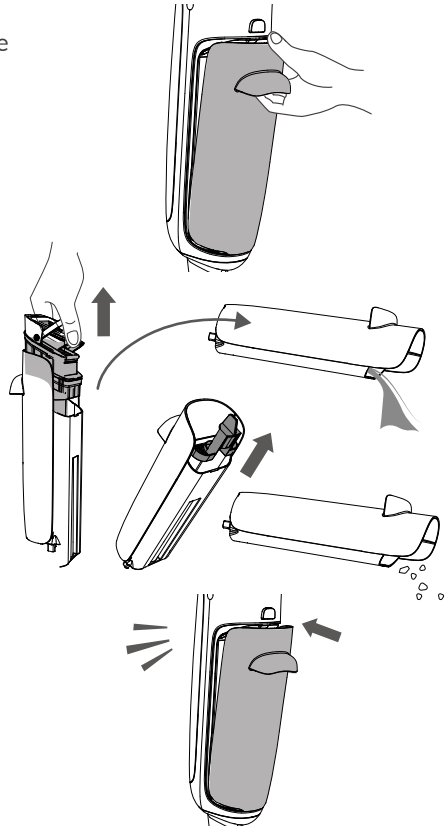

## 4.7 Charging and Self-Cleaning

1. Place the main body onto the charging dock. The device will shut down automatically, and a voice prompt will announce: "Start charging."  
(When battery is low: voice prompt says "Low battery.")
2. Short press the self-cleaning button to start or exit self-cleaning mode.
3. Once self-cleaning is complete, a voice prompt will say "Self-cleaning finished." Please empty the dirty water tank promptly to avoid odors.

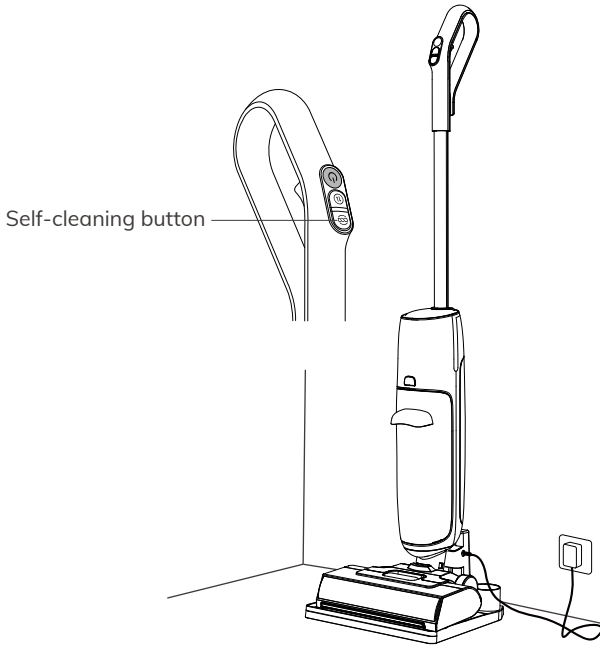

### Tip:

- \* This appliance includes a high-performance lithium-ion battery. To maintain battery health, keep the device on charge during daily use.
- \* Do not lift the main body during self-cleaning. Ensure both the clean and dirty water tanks are installed correctly.
- \* After cleaning, return the machine to the charging dock promptly to avoid water stains on the floor.

## 5.1 Recommended Maintenance Frequency

To keep your floor washer performing at its best, refer to the following table for routine maintenance:

Component	Clean Frequency	Replace Frequency
Roller Brush	As needed	Every 3 months
Filter Sponge	As needed	As needed
Dirty Water Tank	As needed	N/A
Clean Water Tank	Every 1 month	N/A
Brush Head & Wastewater Duct	Every 1 month	N/A
Charging Dock	As needed	N/A
Charging Pins	As needed	N/A
Roller Brush Cover	Every 2–4 weeks	N/A

### Tip:

- \* Before cleaning or maintaining the charging dock and the main body, make sure the charging dock is powered off and the main body is turned off or not operating.
- \* Replacement frequency depends on actual usage. If any part shows signs of excessive wear, replace it promptly.
- \* Always use original parts; otherwise, warranty services may not be guaranteed.
- \* If the product will not be used for an extended period, fully charge it, unplug the power cord, and store it in a cool, dry place away from direct sunlight or humidity. Recharge at least once every 3 months to avoid battery over-discharge.

## 5.2 Cleaning the Main Body

Before cleaning, remove the main body from the charging dock and turn it off. Wipe the main body with a soft, dry cloth.

### 5.3 Cleaning the Dirty Water Tank and Filter

1. Remove the dirty water tank and take out the filter assembly.
2. Remove the filter holder from the filter assembly, then take out the filter sponge from the filter holder. Rinse the filter assembly, holder, and sponge thoroughly with clean water.
3. Then, remove the mesh filter from the dirty water tank. Use the cleaning brush to remove any debris (such as hair) stuck on the filter. If the filter is heavily soiled, rinse it thoroughly with water and shake off any remaining water.
4. Allow all components to dry completely before reassembling.

#### Tip:

- \* Drying the filter sponge may take time. Consider using two sponges alternately.
- \* Ensure all components are completely dry before reuse.
- \* Avoid touching the surface of the filter sponge with brushes or sharp objects, as this may cause damage.

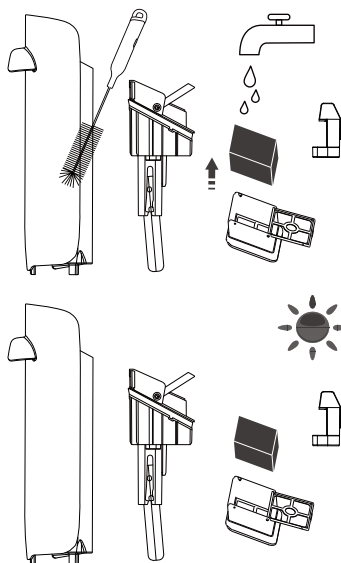

### 5.4 Cleaning the Roller Brush

1. Press the release button and lift upward to remove the roller brush cover. Pull up the roller brush lock and take out the roller brush.
2. Pull open the roller side cover. Use the cleaning brush to remove tangled debris, then rinse the roller brush and cover with water.

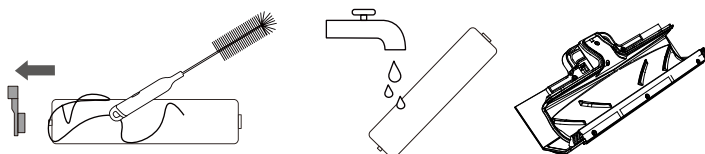

3. Shake off excess water from the roller brush, then place it in the dock's rear storage slot to dry.

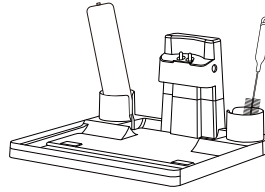

4. After drying, reinstall the roller brush.

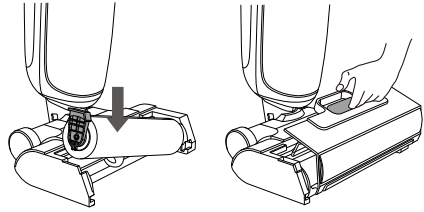

## 5.5 Cleaning the Wastewater Duct

1. Turn off the main body and place it securely. Remove the dirty water tank, clean water tank, and roller brush.
2. Use the cleaning brush to clean the roller brush slot and Wastewater duct.
3. Reinstall the roller brush, clean water tank, and dirty water tank.

### Warning:

Do not rinse the brush head or charging dock directly with water.

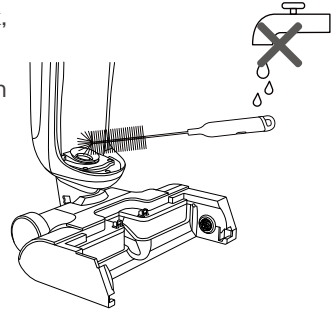

## 5.6 Cleaning the Charging Dock

Disconnect the charging dock from power. Wipe the surface and charging pins with a soft, dry cloth.

### Tip:

Do not rinse the charging dock directly with water.

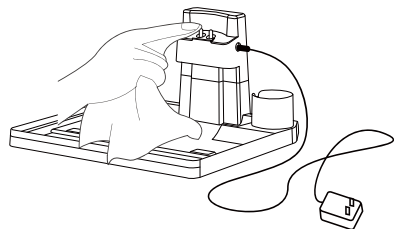

## 5.7 Replacing the Floor Brush Squeegee

### Disassemble

1. Power off the machine. Remove the dirty water tank and the roller brush.
2. Flip the floor brush head over so the bottom faces up and lay it flat on the ground.
3. Use a screwdriver to remove the screws on the T-shaped cover.
4. Remove the T-shaped cover. Press down on one side of the squeegee and pull it out by pinching the edge.
5. Take out the two side wheels. Use the cleaning brush to remove dirt and debris from the bottom slot of the floor brush.
6. Rinse the squeegee, T-shaped cover, and wheels thoroughly and shake off excess water before reassembling.

1

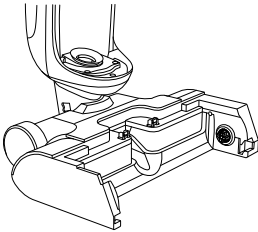

2

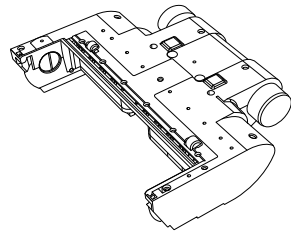

3

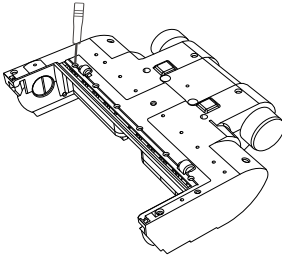

4

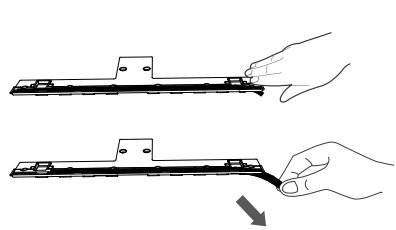

5

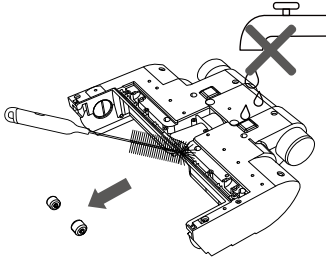

6

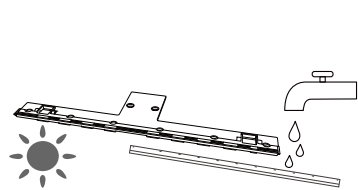

## Assembly

1. Insert the squeegee from the bottom up through the first clip, with the toothed side facing upward.

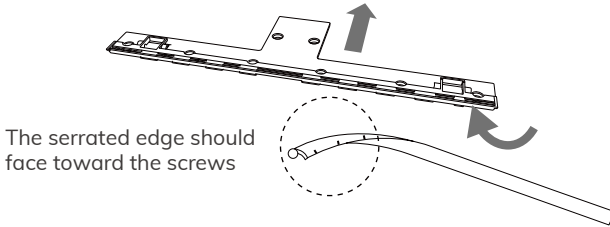

### Note:

Ensure the scraper strip is installed in the correct direction — the serrated edge should face toward the screws. Incorrect installation may reduce cleaning performance.

2. Pinch the top of the squeegee and gently pull it upward and diagonally until it is fully seated in the groove.

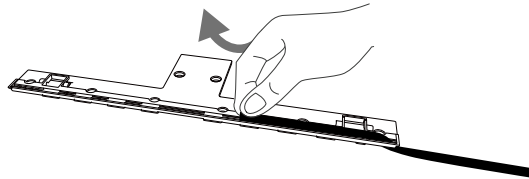

3. Place the wheels into the wheel slots, reattach the T-shaped cover, and secure it with screws.

## 6.1 Malfunction Status and Solutions

When a malfunction occurs, the machine's indicator light will flash red and a voice alert will play. Use the table below to identify and resolve the issue.

Status	Possible Causes and Solutions
The main body does not operate	<ul style="list-style-type: none"> <li>• Low battery. Please charge before use.</li> <li>• Suction inlet is clogged or roller brush is jammed. Clear any obstructions and restart the appliance.</li> <li>• The dirty water tank is full. Please empty the tank.</li> </ul>
Suction power is weak or abnormal noise occurs	<ul style="list-style-type: none"> <li>• Suction inlet is clogged or roller brush is jammed. Clear any obstructions and restart the appliance.</li> <li>• The filter sponge in the dirty water tank is dirty. Please clean it.</li> <li>• The dirty water tank assembly is not properly installed. Check and reinstall.</li> <li>• Battery voltage is too low. Charge the appliance promptly.</li> </ul>
Display does not light up during charging	<ul style="list-style-type: none"> <li>• Check if the power adapter is properly connected.</li> <li>• Battery is fully charged; it may have entered sleep mode.</li> </ul>

## 6.2 Voice Prompts & Error Codes

Voice Prompt	Display Behavior	Cause	Solution
"Please check the main brush"	Current battery level flashes for 5s	Roller brush malfunction	Inspect and clean the roller brush
"Please empty the dirty water tank"	Current battery level flashes for 5s	Dirty water tank full	Empty the dirty water tank
"Low battery"	Battery icon flashes	Low battery	Place the device on the charging dock for charging
	Code 12 flashes for 10s	Undervoltage	

Voice Prompt	Display Behavior	Cause	Solution
"Beep Beep Beep"	Code 01 flashes for 10s	Fan malfunction	Replace the fan
	Code 02 flashes for 10s	Roller brush obstructed	Clean the roller brush
	Code 03 flashes for 10s	Water pump malfunction	Replace the water pump
	Code 04 flashes for 10s	Fan short circuit	Replace the fan
		Roller brush short circuit	Replace the roller brush motor
		Water pump short circuit	Replace the water pump
	Code 05 flashes for 10s	Charging error	Check the charging dock and charging pins
	Code 06 flashes for 10s	Battery overheating	Leave the device in a cool environment for 30 minutes
	Code 07 flashes for 10s	Voltage anomaly	Replace the battery
	Code 08 flashes for 10s	IC overheating	Leave the device in a cool environment for 30 minutes
	Code 10 flashes for 10s	Battery cell voltage anomaly	Replace the battery
	Code 11 flashes for 10s	NTC short circuit or disconnected	Replace the battery
Code 13 flashes for 10s	Charging dock undervoltage	Inspect or replace the charging dock	

**Note:**

If an error is not resolved in time, the device will automatically shut down or enter shutdown mode.

For component replacement, please refer to the "Customer Support" section and contact after-sales service.



